



HSF

Recommended P.C.B Layout(Top Side)
(PCB BOARD TOLERANCE±0.05) 

NOTES:
 Rated Current:5 AMP
 Rated Voltage:300 V
 Contact Resistance:20 mΩ max
 Withstand Voltage:2000 V AC/DC
 Insulation Resistance:500 MΩ min
 Operation Temperature:-40°C to +105°C
 Wire Range:20~24 AWG 
 Insulator Material:PA66 +20%GF(Ul94 V-0)
 Cover Material:PA66 +20%GF(Ul94 V-0)
 Push Pole Material:PA66 +20%GF(Ul94 V-0)
 Terminal Material:Phosphor Bronze
 Terminal Plating:Bright Tin Plated Over Nickel



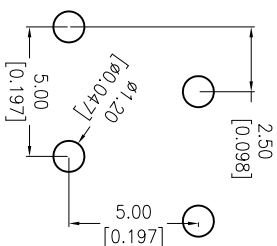
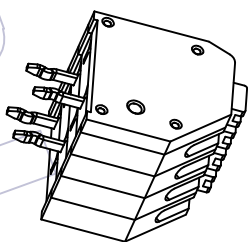
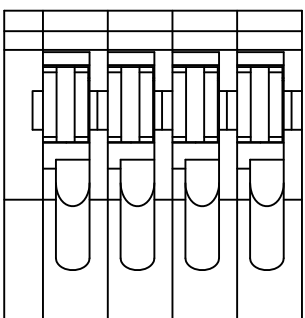

Ordering Information:

MH 250 - 115 S XX X XX 1 N

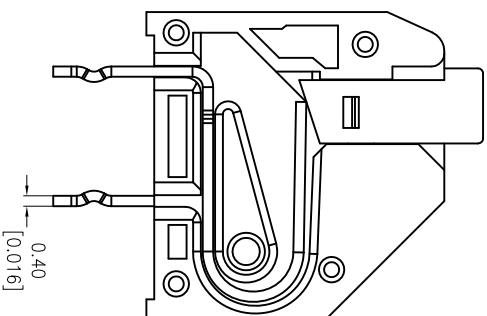
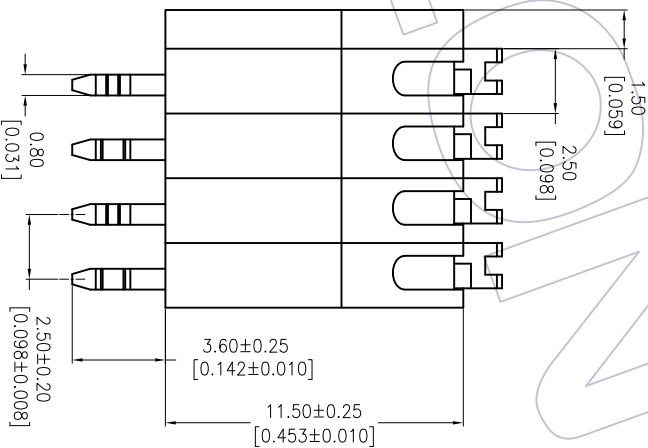
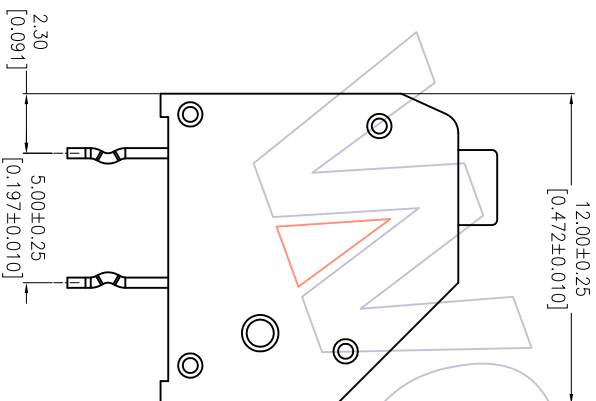
Pitch 250=2.50 Housing High 115=11.50 No.of Pins Color Contact Plated
 G=Grey SN=Bright Tin
 A=Green



| | | | | | | | | | | | | |
|-----|------------|--------------------------|---|---------------|---------|------------|--------------|-----|-------------------|--|---|--|
| REV | DATE | MODIFICATION DESCRIPTION | CHANGE | OPERATION | DRAW | DATE | SCALE | FIT | PART NO. | TITLE: 2.50mm Pitch Merge Terminal Block Customer NO. | WCON-Dongguan Http: www.wcon.com Tel: +86 769 85358920 Fax: +86 769 85358915 E-mail: sales@wcon.com | WCON-Kunshan Tel: +86 512 57468408 Fax: +86 512 57468468 E-mail: sales@wcon.com |
| A2 | 2015/12/09 | Modify |  | XX ±0.40 | JYHuang | 2015/12/09 | UNIT mm | A4 | MH250-115SXXXXX1N | | | |
| A1 | 2015/09/08 | Modify |  | XXX ±0.25 | CHECK | DATE | SIZE inch | 1/1 | | | | |
| A0 | 2015/07/13 | NEW | | XXXX ±0.15 | APPROVE | DATE | SHEET | | | | | |
| REV | DATE | MODIFICATION DESCRIPTION | CHANGE | Angle ± 3° | APPROVE | DATE | PROJ. | | | | | |

WCON

Http: www.wcon.com

WCON-Dongguan
 Tel: +86 769 85358920
 Fax: +86 769 85358915
 E-mail: sales@wcon.com

WCON-Kunshan
 Tel: +86 512 57468408
 Fax: +86 512 57468468
 E-mail: sales@wcon.com